

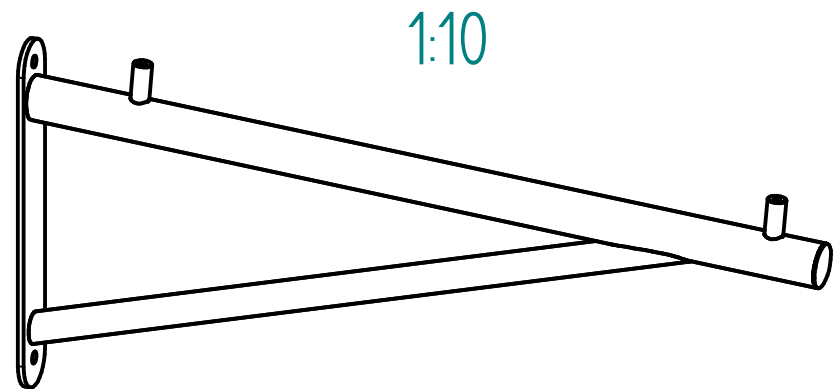

Schnitt A-A

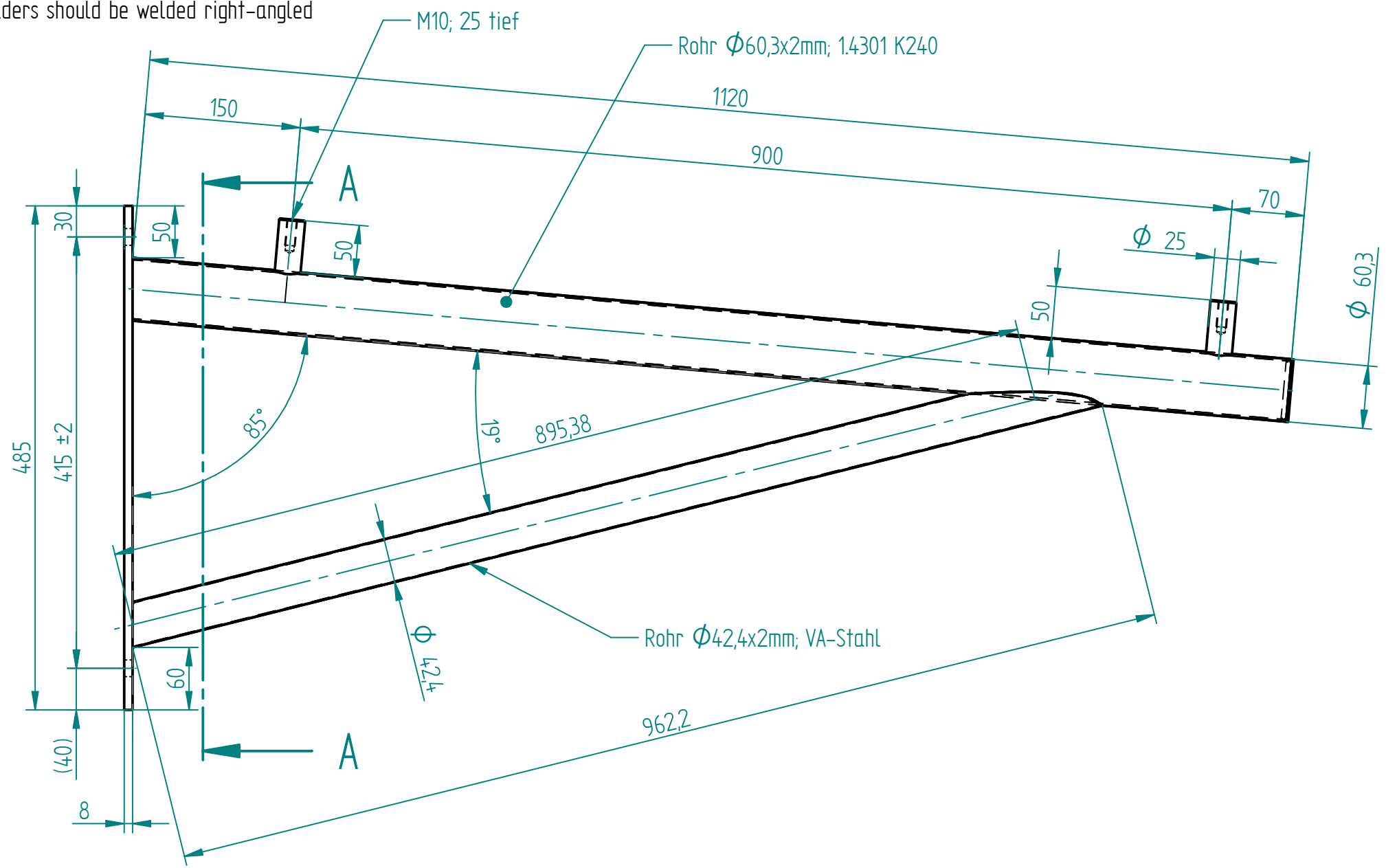
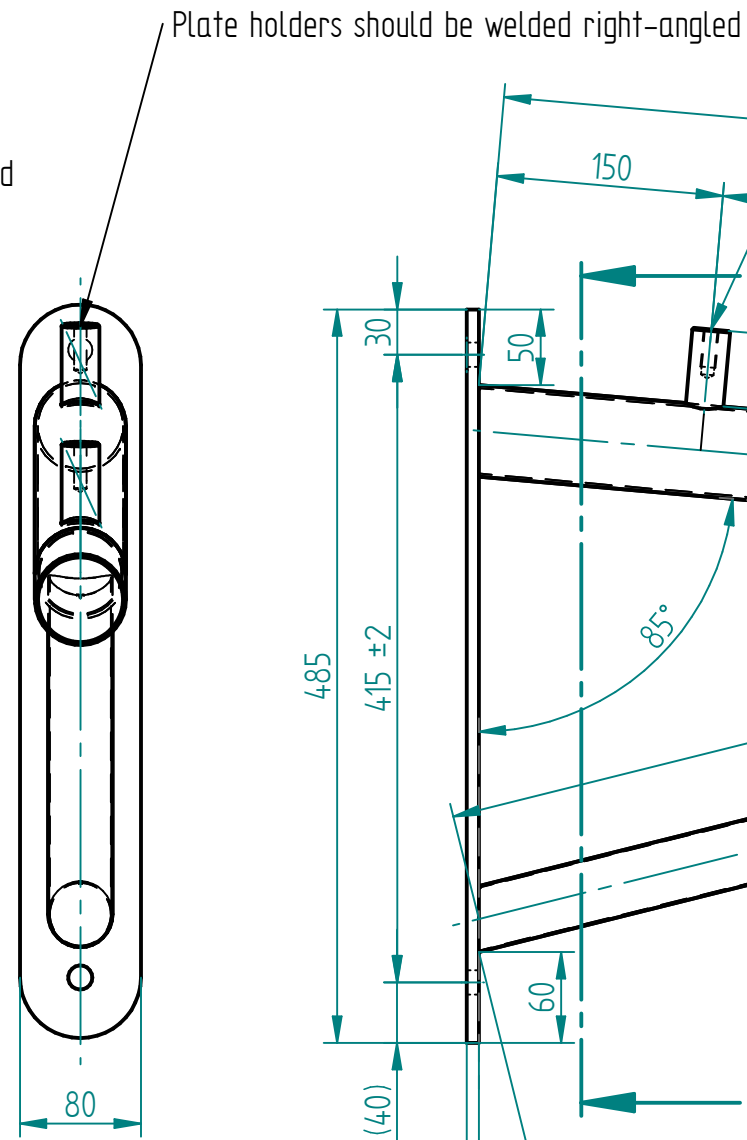
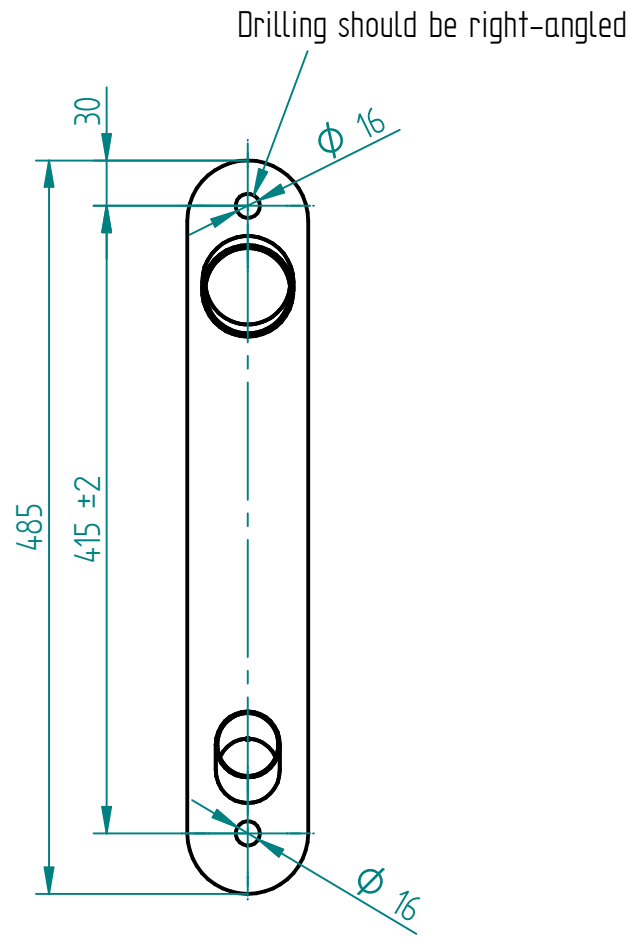

	NAME	DATE		
gezeichnet	Technik	27.11.2017		
geprüft				
Oberfl. Beschläge	K240		Kunde: -----	
Stückzahl	-			
Werkstoff	1.4301		SIZE	Benennung: Trager Trave $\phi 60,3$ WL = 1150-1350
			A3	REV
			FILE NAME: Traeger_60,3-WL_1150-1350_Probe.dft	
			SCALE: M 1:5	WEIGHT: